

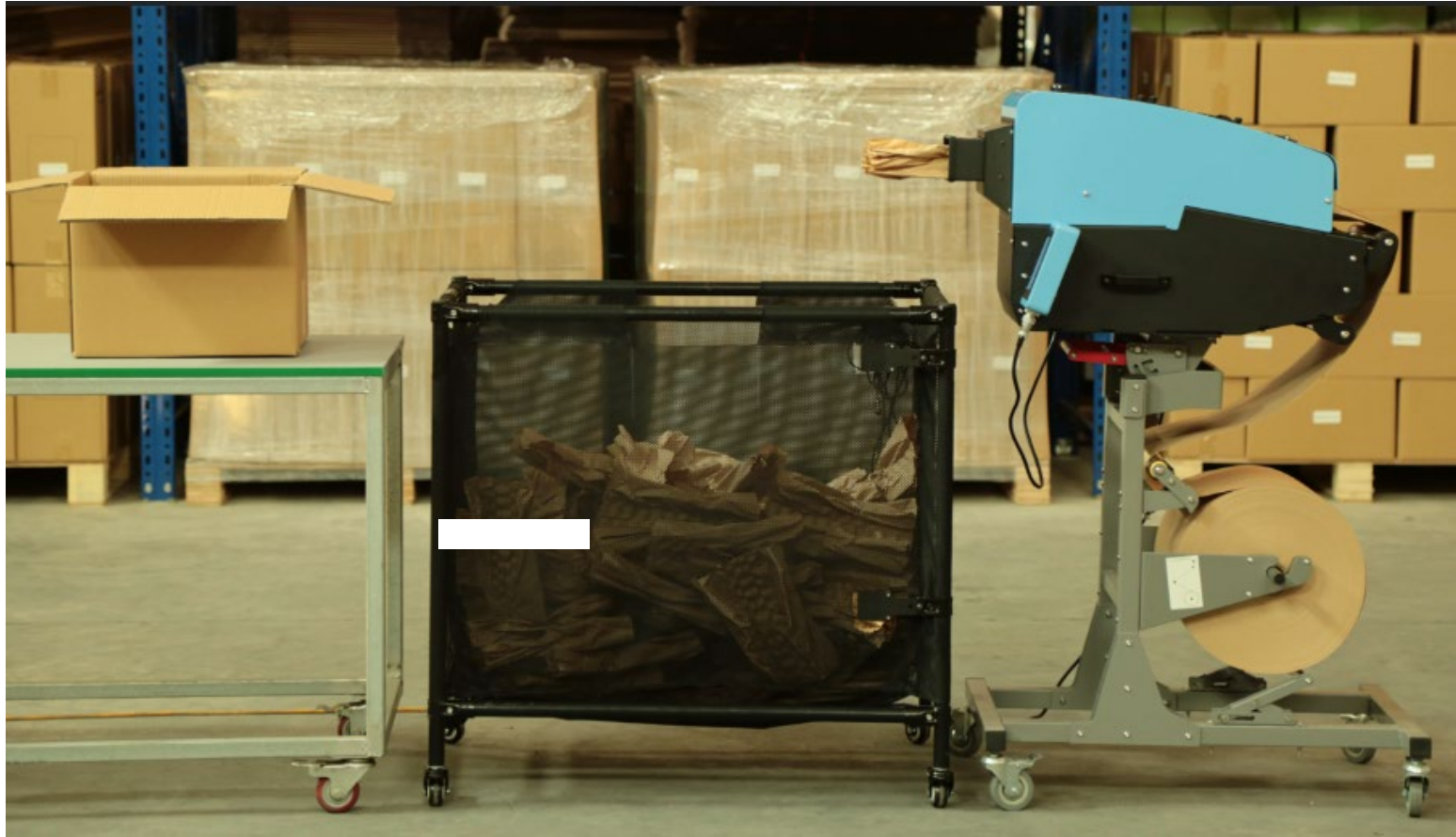

# PRIMEPAC

*making it easy!*

## PAPER CUSHION MACHINE



### PRODUCT SIZE

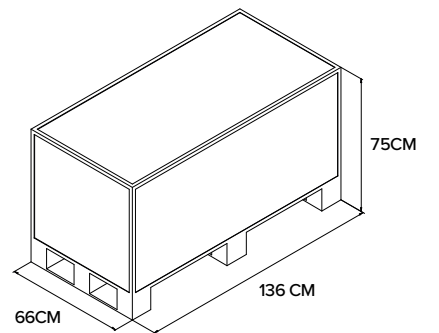
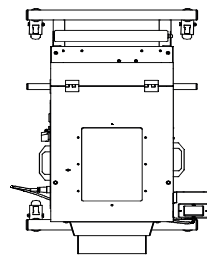
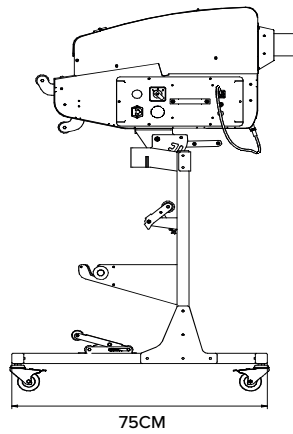
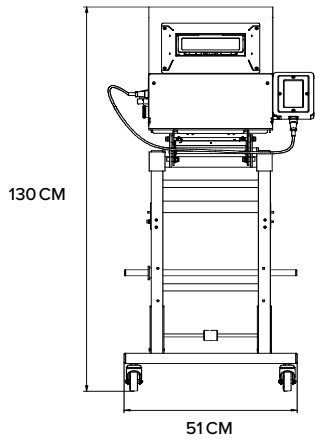

Package size of single machine - Plywood

☎ 0800 277 772  
🌐 [www.primepac.co.nz](http://www.primepac.co.nz)

✉ [sales@primepac.co.nz](mailto:sales@primepac.co.nz)  
📍 L3 1/61 Constellation Drive, Rosedale, Auckland



# PRIMEPAC

*making it easy!*

## PRODUCT SPECIFICATION

Code 4048

### PRODUCT PARAMETERS

Power: 350W

Voltage: 200~230V or 100~120V

Shell material: Metal alloy

Paper application: Before unfolding 70CM, After folding 30CM

Net weight: 78KG Gross weight: 110KG

### PRODUCT FEATURES

Easy to operate, just refer to the manual

Multimode function

Small size, modular design

Warranty period: 12 months

Customizable: color, logo

Multiple proprietary patented products

Certificate: CE

## GENERAL DIMENSION TABLE OF PAPER

Model	Colour	Gram weight	Width	Length	Fold
YP-G-30-70-350	Natural	70g	700mm	350m	300mm
YP-G-30-80-250	Natural	80g	700mm	250m	300mm
YPW-G-30-80-250	White	80g	700mm	250m	300mm
YP-G-30-110-190	Natural	110g	700mm	190m	300mm

0800 277 772  
www.primepac.co.nz

sales@primepac.co.nz  
L3 1/61 Constellation Drive, Rosedale, Auckland



# PRIMEPAC

*making it easy!*

- Customized: Gram weight, length.
- Standard packing: No carton, set of bags.
- Material (optional): Recycled high strength paper (50HG).
- If double-layer paper is required, select model NP-EC pro.

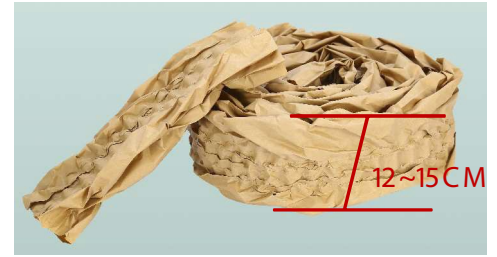

## PACKAGING PARAMETERS OF PAPER

Dimensions:1200x1000x1050mm.

24 rolls / pallet

